

RYOBI[®]

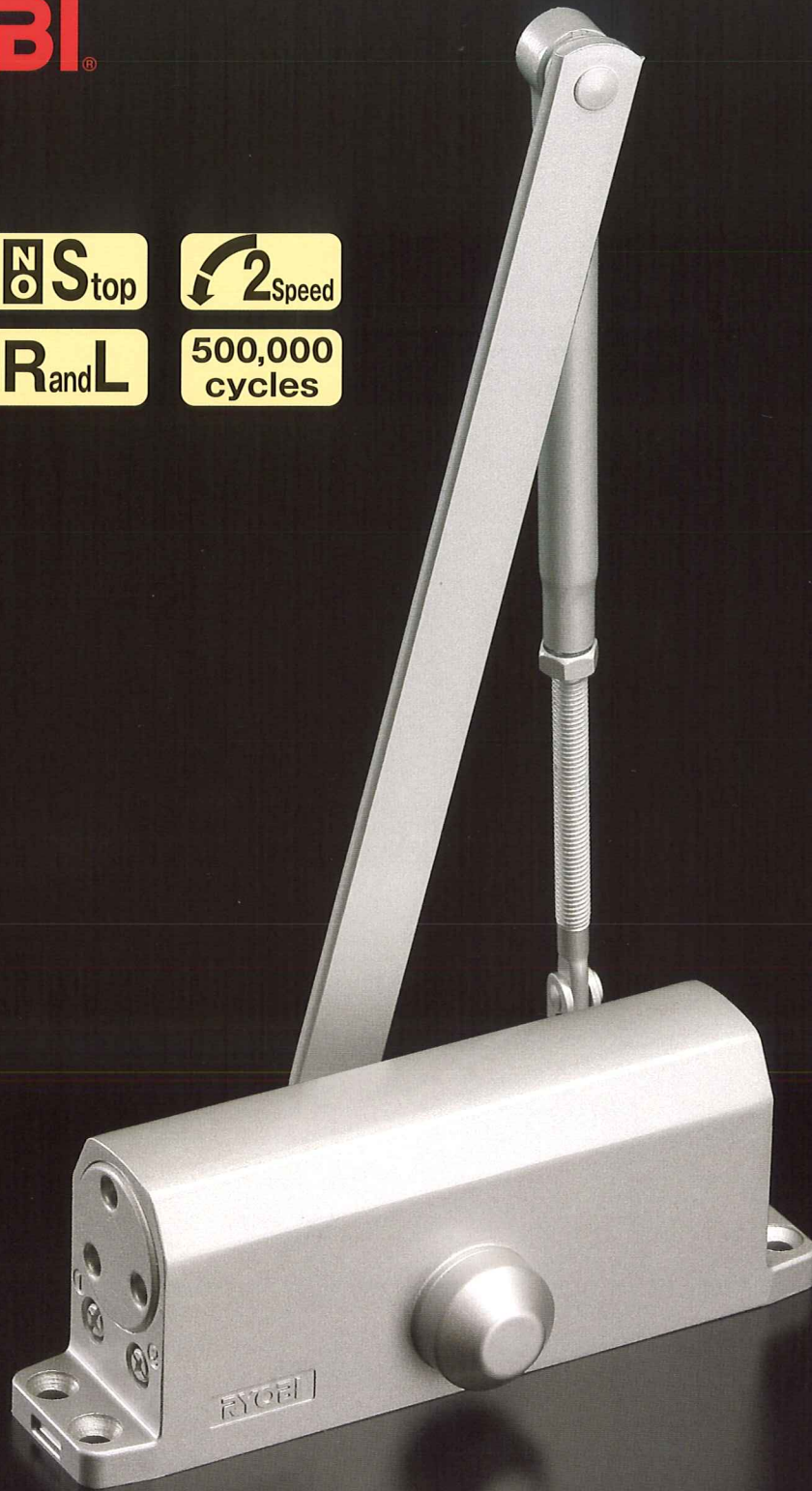

REGISTERED TO
ISO 9002
CERTIFICATE
NO. A5324



**Surface Mounted
Door Closer**

RYOBI 9903

9903

■ FULL HYDRAULIC CONTROL

This feature controls the door through the entire opening and closing sequence, and an adjustably controlled latch speed through the closing cycle.

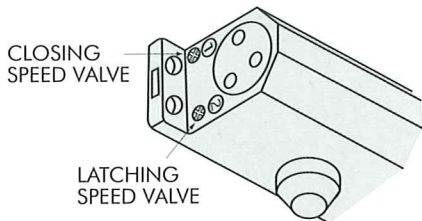
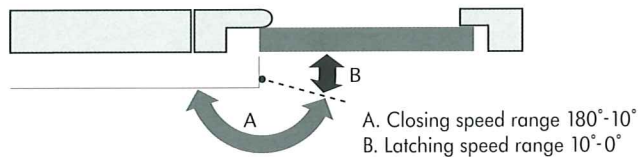

■ HIGH DURABILITY

Ryobi door closers are manufactured using high strength pressure die-cast aluminum body's, precision machined components and reversible rack & pinion mechanism. The model is guaranteed to 500,000 opening/closing cycles for extended trouble free service.

■ EASY INSTALLATION

Installation is made quick and easy by using the mounting template. The 9903 door closer is available standard mounting.

■ ADJUSTMENT

Closing and latching speeds are quickly adjusted to suit your individual need by rotating the two speed control valves.

■ PERIODIC MAINTENANCE

Thanks to the high precision components and quality of manufacture, the 9903 door closer does not require any maintenance other than a regular inspection of the fixing.

■ LATCHING POWER ADJUSTMENT

By changing the position of the frame arm of the foot bracket the closing force of the latch can be increased or decreased. This adjustment can be achieved whilst the foot bracket is in position.

■ OPTIONAL COVER

Designed to meet the requirements, the 9903 door closer has an optional cover.

■ VARIOUS FINISH

The 9903 door closer is available in : Silver, Dark Bronze, Metallic Lemon Gold, Black, or White color finishes. Custom colors may also be available.

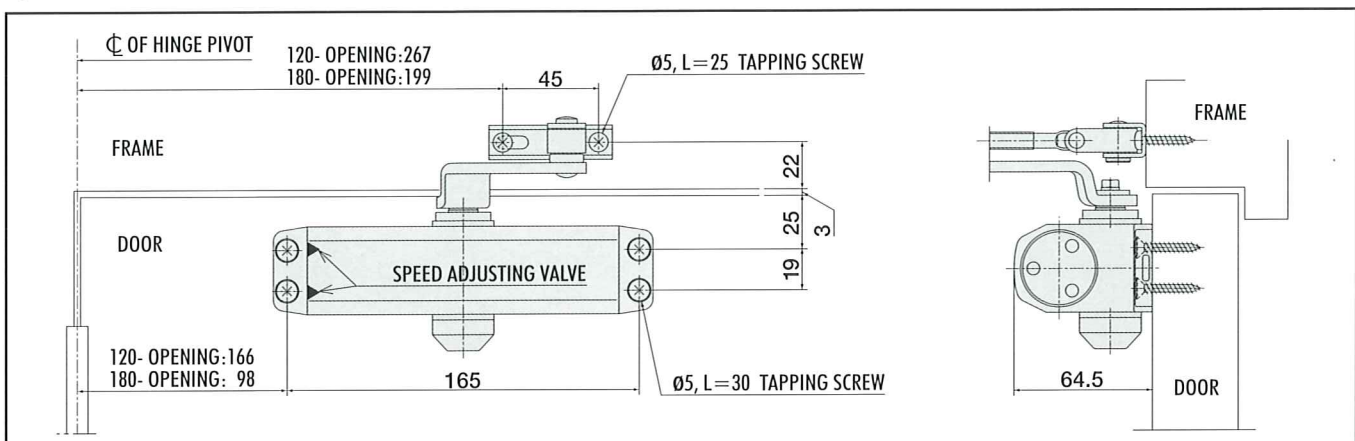

◆ OPTIONAL ACCESSORIES

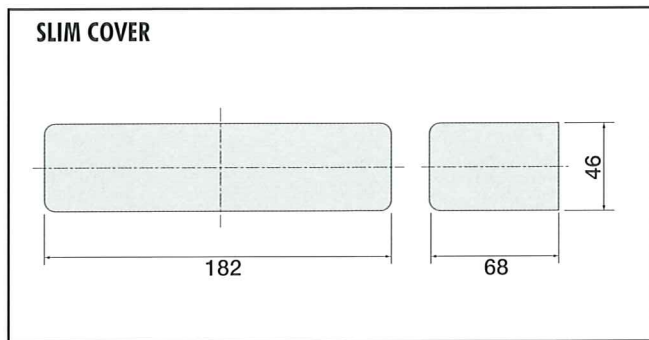
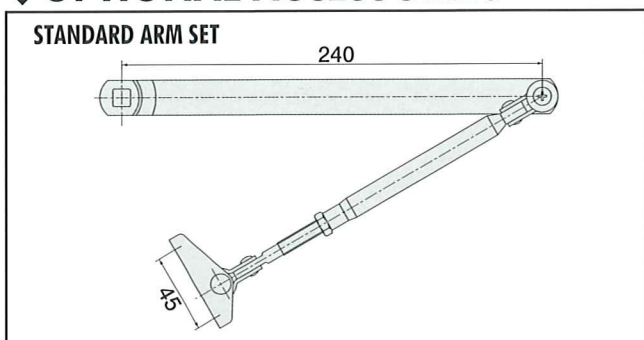

SIZE	STANDARD APPLICATION		MAX. DOOR WEIGHT	MAX. DOOR WIDTH
	WITHOUT COVER	WITH COVER		
3	9903	9953	≦65KG	≦965mm

RYOBI LIMITED

5-2-8 Toshima, Kita-ku Tokyo 114-8518, Japan
Tel. 81-3-3927-5536 Fax. 81-3-3927-5527

<http://www.ryobi-group.co.jp/en/>

RYOBI is a registered trade mark of Ryobi Limited